

Description

2-way, 2 output CATV distribution amplifier

Feature

- Use Micro-tube pre-amplify and low noise Philips power doubler module(BGD814).
- EQ, ATT have fixed or adjustable
- Output splitter(FZ110) or coupler(FP204) can plug change to make engineering debug more agile
- More powerful, less consumption



Specification

Frequency bandwidth	Forward	87-860MHz
	Reverse (option)	5-65MHz
Gain	Forward	30dB
	Reverse (option)	12dB
Noise figure	Forward	≤10dB
	Reverse (option)	≤12dB
Output level	Forward	102dBuV
	Reverse(option)	110dBuV
CTB	Forward	≥65dB
CSO	Forward	≥63dB
Return loss	Forward	≥15dB
	Reserve	≥15dB
Flatness in band	Forward	±0.75dB
	Reserve	±0.75dB
Input voltage	Ac:135v-250v,or Ac:35v-90v	
Consumption	30w	
Dimension	260mmx210mmx120mm	

Test condition

At the range of 750MHz (112.25~743.25MHz) when testing the C/CTB and C/CSO, set 79 PAL-D imitate TV channels signal; set 93PAL-D imitate TV channels signal at the range of 862MHz (112.25~855.25MHz).

Choose f1=65MHz, f2=63MHz and f3=57MHz to test when measuring index of max output level in upgo transmission.

The index of "Carrier to Second Order Intermodulation Ratio" is tested under the condition of 110dBuV output level, and choose f1=10MHz, f2=60MHz and f3=50MHz three point to test.

Principle Drawing

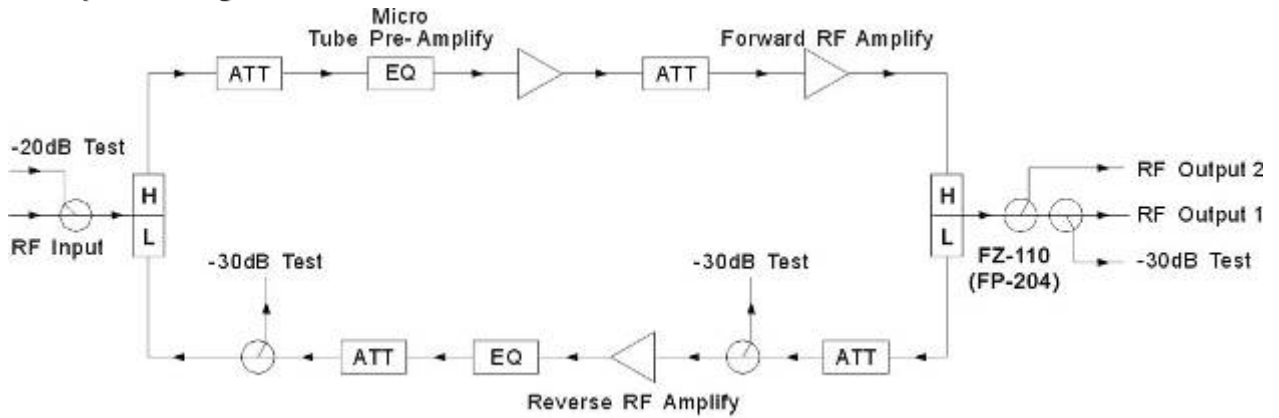

Test printing

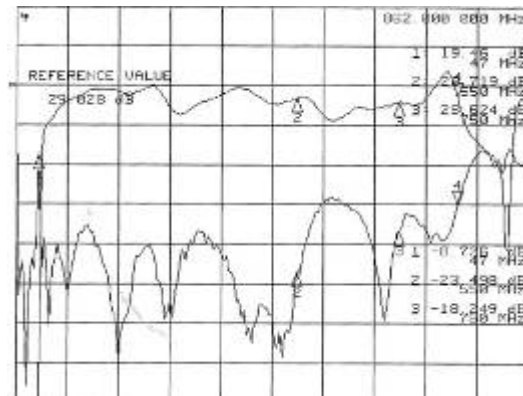

--END--